

Bow Tie Antenna Design for GPR Applications

Saeid KARAMZADEH¹

Oğuz Furkan KILIÇ²

Ahmet Said HEPBİÇER³

Fatih DEMİRBAŞ⁴

Abstract

In the recent years, radar systems have developed rapidly. Among developing radar systems, Ground Penetrating Radar (GPR) is also located. GPR systems are used quite effectively in civilian life, military operations and commercial activities. This article contains one of the optimization works which is ensued in the antenna side which the most important part of GPR. In this way, a bow tie antenna will be designed, simulated and fabricated. The fabricated antenna results agree well with the simulation analysis.

Keywords: GPR, Bow-Tie Antenna

INTRODUCTION

The system used to obtain information about an object which is behind a barrier, is the special type of Radar called Ground Penetrating Radar (GPR). With using the radar systems, it is possible to get information

about location, distance and material type of objects. At first radio waves were used in radar systems, microwave and very High Infrared segments of electromagnetic spectrum are preferred to operate in modern

¹ Department of Electrical and Electronics Engineering, Istanbul Aydın University, Istanbul, karamzadeh@itu.edu.tr,

² Department of Electrical and Electronics Engineering, Istanbul Aydın University, Istanbul, oguzfurkankilic@stu.aydin.edu.tr,

³ Department of Electrical and Electronics Engineering, Istanbul Aydın University, Istanbul, ahmetsaidhepbicer@stu.aydin.tr

⁴ Department of Electrical and Electronics Engineering, Istanbul Aydın University, Istanbul, fatihdemirbas@stu.aydin.edu.tr

world [1]. Through the agency of GPR applications, information about the buried objects and behavior of electromagnetic waves that cross along the obstacle could be analyzed [2]. Civil and military sections are the most popular areas for the GPR applications. In military area, it is commonly used for finding unexploded bombs, underground warehouses, bomb shelters, discovering enemy communication channels, secret rooms [3]. In civil life GPR is commonly applied for finding, buried pipes and undetected voids. Together with these, GPR is used to find people behind the rubble also [4-6].

An antenna in the GPR systems is needed as a transmitter and receiver or both of them at the same time (monostatic Radar). Transmitter antenna generate electromagnetic wave and this wave's scatter to object that buried under the soil or behind the wall. Wave's speed is according to medium's permittivity. When the wave hits the object, some part of wave is reflected from that and receiver antenna catches this part of wave. GPR system principle is shown in figure1.

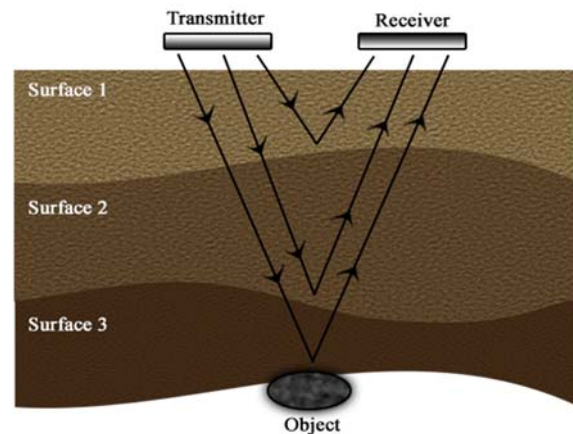

Figure 1. General working principle of GPR.

Antenna's range-resolution is quite significant in terms of detecting objects in deeper underground or getting more reliable information about them.

Physical features of antenna also play an important role in GPR systems. If antenna is small and light, it provides convenience in terms of usability of the system.

The efficiency of the antenna is also an important part of the system. The high efficiency provides reliable and more information. Having better antenna efficiency depends on the optimization works in antenna's physical features. [7]

There are a lot of antennas like, horn antenna, Vivaldi antenna and microstrip antennas that are used in GPR systems [8].

Biconic, Bow-Tie and Vivaldi antenna shapes demonstrated in Figure 2. Using circular polarized antenna is recommended in the literature for getting better result in multilayer medium [9-11].

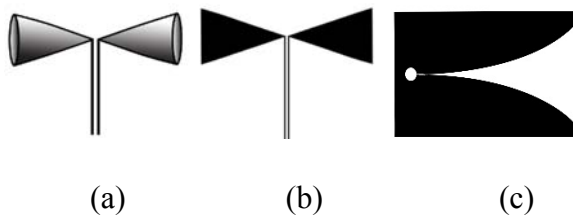

Figure 2. Some GPR antennas; (a) Biconic antenna, (b) Bow-tie antenna, (c) Vivaldi antenna.

The main features taken into consideration to select the most suitable antenna are the center operating frequency of the antenna, gain, bandwidth and also antenna size.

When central operating frequency is adjusted to minimum 1 GHz, bionic, TEM Horn and Vivaldi antennas have to be quite large structures. It is shown that Bow-Tie antenna is the optimal antenna in terms of size, among

mentioned antennas. When the mentioned antennas evaluated in term of gaining, these antennas have points where their gaining's are pretty enough in terms of their capacities. Bow-Tie antenna is determined the best suitable antenna type to be used in this work. Bow-Tie antenna is determinative for the use of GPR applications in terms of being light considering its design, being smaller when it is compared to other antenna types in constant frequency and in having higher gain in another similar comparison. In this paper, firstly a new Bow-Tie antenna will be designed. In the light of the results obtained during the simulations performed a performance improvement of the antenna will become more efficient. These results which will be revealed by analyzing the antenna parameters in a detailed way and by working on these parameters will provide an insight to the antenna designs in the future. The simulation and fabricated results will be presented in next steps.

GEOMETRY OF ANTENNA

Geometric structure of the proposed antenna is shown in Figure 3.

In the proposed bow-tie antenna used as an epoxy material $\epsilon_r = 4.4$ which is FR4

substrate. Dimensions are 195 x 235 x 0.8 mm³. The antenna feed 50 Ohm SMA connector. the antenna feed path length $h = 150$ mm. $L_x = 110$ mm affecting the antenna's efficiency and operating frequency largely, and length of L_y is 70 mm. Made in different designs, the optimum angle θ is defined as $\theta = 35^\circ$.

As a result of the changes made on all parameters, the different operating frequency and bandwidth could be obtained according to the antenna size and geometry.

RESULTS AND DISCUSSION

The proposed bow-tie antenna individually by considering all parameters were studied, simulated and optimized by Ansoft HFSS ver.15. Initially, the improvements had discussed the antenna S11 parameter's graphics. Improvements made by considering the antenna size done and is as follows.

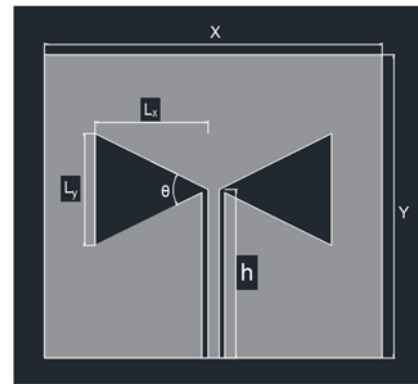

(a)

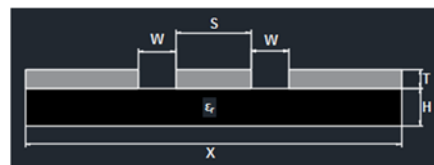

(b)

Figure 3. The geometric structure of the proposed antenna. **(a)** Top view. **(b)** Side view.

Table I. Antenna diameters

Paramet ers	Ant .1	Ant .2	Ant .3	Ant .4	Ant .5
Y (mm)	235	235	235	215	195
X (mm)	235	235	235	235	235
Lx (mm)	100	110	110	110	110
Ly (mm)	90	90	70	70	70
h (mm)	150	150	150	150	150
θ (degree)	48	44	35	35	35
H (mm)	0.8	0.8	0.8	0.8	0.8

Table I shows the dimension optimization during the design process step by step. To every improvement works in the Table I it can be observed; in the first antenna (Ant.1) X and Y values are equal to each other and are 235 mm. Lx and Ly values were determined in the form of 100 mm and 90 mm. Triangle-shaped structures within the antenna affect the antenna's S11 value and gain. With the improvement in the second antenna (Ant.2) angle θ reduced and a larger triangle structure is formed by this step. The third antenna (Ant.3) X and Y values are kept constant at 235 mm Ly = reduced to 70 mm, and the θ angle reduced to 35 degrees that changed the current distribution. Thus antenna S11 values will continue to give better results. Each new modification, the antenna while moving a little further, the antenna is desirably smaller. Therefore, antenna of the triangle parts of are made by cutting the top part of the structure that includes touching the substrate is set at X = 215 mm. Therefore, parts of the antenna excluding the triangle made by cutting the top part of the structure including the substrate is set at X = 215 mm. This is happening in S11 values have made more efficient. Before taking final shape of the antenna, cut again, this time from the bottom of the antenna with

the same method it has been reduced to 195 mm X = value. Fifth antenna (Ant.5) gives the best results according to the obtained results. The figure 4 represents the five antenna's simulation results of S11 chart. The S11 parameters of simulated and fabricated of Ant.5 is shown in figure 5.

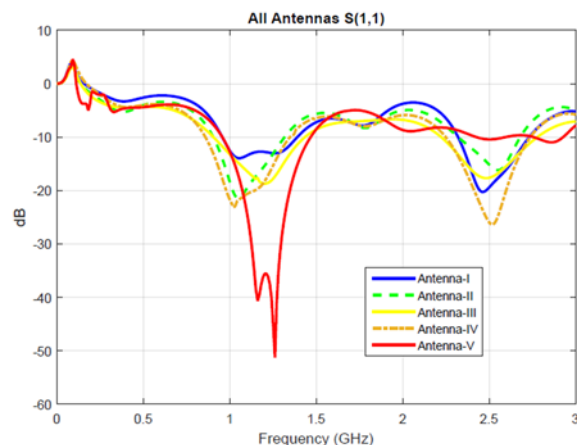

Figure 4. S11 graphs of simulated antenna.

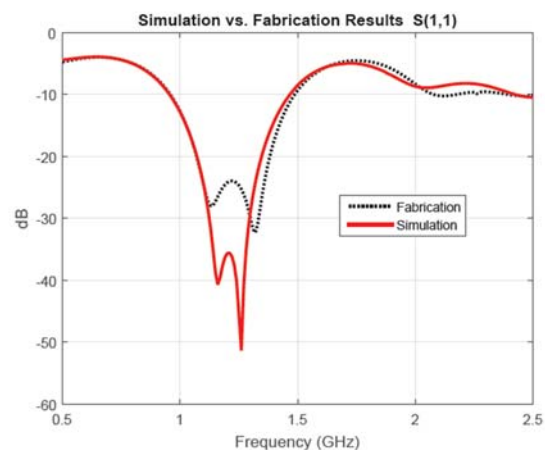

Figure 5. Measured and simulated diagrams of S11 parameter for proposed antenna (Ant.5).

The antenna bandwidth starts from the 0.8 GHz; according to the first simulation, the bandwidth is widened. When the result of improvements of the third antenna, changes in a significant improvement in low frequency, but there is a second resonance at higher frequency. But the goal; to be able to get a good result at low frequency. The result of the fourth antenna in compare with third one, despite downsizing is protected. In the proposed antenna (Ant.5) by last modification the best result is acquired. Below -10 dB of S11 parameter in the frequency range 0.9-1.5 GHz, by means 0.6 GHz bandwidth was obtained. The antenna is designed in the last step; it is seen that the current distribution is homogeneous. As clear in figure 6 making an effective and uniform radiation in all areas of the antenna also been observed. The fabricated bow tie antenna is shown in the Figure 7.

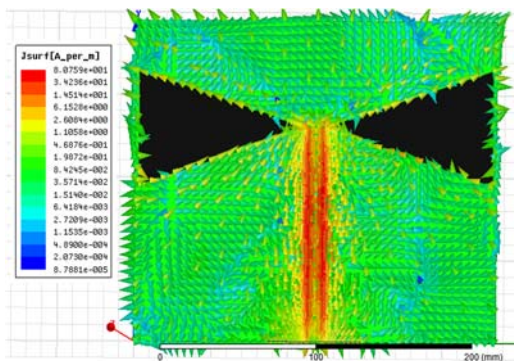

Figure 6. Current distribution demonstration.

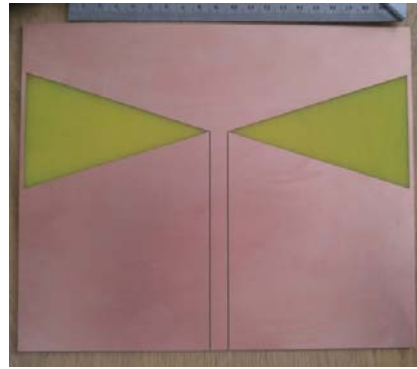

Figure 7. Photograph of fabricated Bow tie Antenna

Figure 8, shows the radiation pattern of the final version of the antenna in different θ and ϕ . 3D graphics and patterns that become the end of the antenna gain values is observed after the simulation as follows in Figure 9.

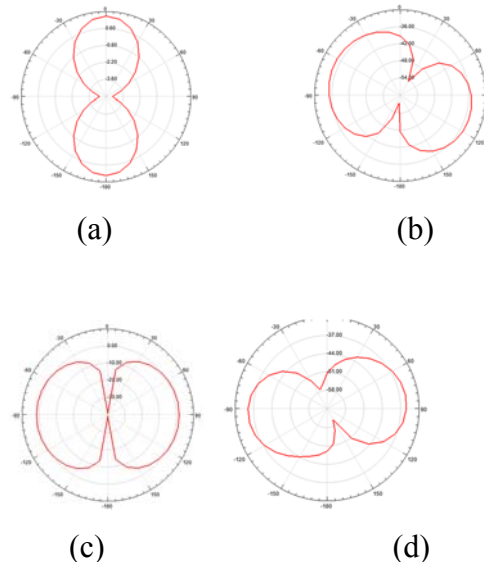

Figure 8. Radiation pattern of proposed antenna at (a) $\phi=0^\circ$, (b) $\phi=90^\circ$, (c) $\theta=0^\circ$ and (d) $\theta=90^\circ$.

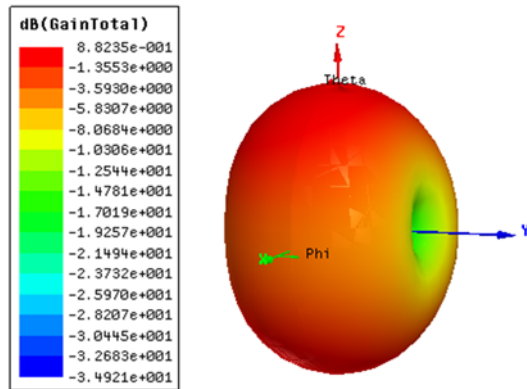

Figure 9. 3D antenna gain plot.

CONCLUSION

The most important part of GPR system is antenna. The system improvements in antenna designing way, will provide better results in GPR applications. Bow-Tie antenna advantages has been evaluated and the results of optimization studies to provide better results for GPR applications were made. These studies were made as a result of the antenna size to be working in both small and optimum operating frequency. As a result, the size of $195 \times 235 \times 0.8 \text{ mm}^3$ was observed that the ideal dimensions. Using Relative permittivity's 4.4 with FR4 epoxy substrate with 0.8 mm thickness, it was chosen the most appropriate in terms of cost. Lx and Ly value of the triangle of the antenna structure 110 mm and 70 mm in length, the angle θ of 35 degrees to give the best results, simulation results were obtained. In light of these values,

and received θ pattern for results, gain values, current distribution and radiation pattern graphical representations show that they are the best at this point of the antenna design.

Specifically designed for this antenna will be able to obtain more detailed and reliable information about an object in the deep. It produced at less cost through downsizing in design work and offers easier use of the opportunity.

REFERENCES

- [1] M.I., Skolnik, *Radar Handbook* McGraw Hill, New York Chicago San Francisco London Madrid Mexico City Milan New Delhi San Juan Seoul Singapore Sydney Toronto, 2008
- [2] J.J., Daniels, "Ground Penetrating Radar Fundamentals", Department of Geological Sciences the Ohio State University, 2000.
- [3] T. H., Bee, "Detection Leakages in Underground Buried Pipe", Department of Mechanical Engineering National University in Singapore, 2009-2010
- [4] S. Karamzadeh, M. Kartal "Detection Improvement of Hidden Human's Respiratory Using Remote measurement methods with UWB Radar", International

- Conference on Telecommunication and Remote Sensing, Netherland, pp.(104-108), July 2013.
- [5] Karamzadeh, S., Kartal, M., Kent, S., & Ashtiyani, A. A. "Optimal Signal Processing Method in UWB Radar for Hidden Human Detection". In EUSAR 2014; 10th European Conference on Synthetic Aperture Radar; Proceedings of (pp. 1-3). VDE. (2014, June).
- [6] Karamzadeh, S., Kartal, M. "*UWB Radar In Hidden Human Detection*" International Journal Of Electronics, Mechanical And Mechatronics Engineering Vol.3 Num 2 pp.(579-583), 2014.
- [7] ORFEUS, "*Test site selection criteria for the Bore-Head Radar test programme*", Work Package: 2100 Document D3a, May 2007
- [8] D. Daniels, Ground Penetrating Radar (2nd ed.). London, UK: The Institution of Electrical Engineers, 2004.
- [9] Karamzadeh, S., Kartal, M. "Circularly polarized 1×4 square slot array antenna by utilizing compacted modified butler matrix and branch line coupler" International Journal of RF and Microwave Computer -Aided Engineering · October 2015
- [10] Karamzadeh, S., Kartal, M." Circularly polarised MIMO tapered slot antenna array for C-band application." Electronics Letters 51(18) · August 2015.
- [11] Karamzadeh, S.,Kartal M., Rafii, V., B.S., Virdee," Modified circularly polarised beam steering array antenna by utilised broadband coupler and 4×4 butler matrix" IET Microwaves Antennas & Propagation 9(9) · April 2015.