

Experimental Studies on Determination of Discharge Capacity of Circular Labyrinth Weirs Located on a Straight Channel

Omer BILHAN¹

M. Emin EMIROGLU²

Abstract

Labyrinth weirs are particularly well suited for spillway rehabilitation where dam safety concerns, freeboard limitations, and a revised and larger probable maximum flow have required replacement or modification of the spillway. Labyrinth weirs with multiple crest elevations can be used in spillway design to confine base flows to a section of the crest and/or satisfy discharge hydrograph requirements. Labyrinth weirs provide higher discharge capacity than conventional weirs, with the ability to pass large flows at comparatively low heads. Over past 50 years many research investigations have considered the hydraulic performance of labyrinth weirs, particularly as dependent on the geometric features. The previous work has improved the design basis for such weirs. In the present study, discharge coefficients were experimentally determined for both sharp crested semi-circular labyrinth weirs and trapezoidal labyrinth weirs of side wall angle ($\alpha=37^\circ$). A comprehensive laboratory study including 9 models was conducted to determine the discharge coefficient of the semi-circular labyrinth weirs. It was found that from this experimental study the discharge coefficient of the circular labyrinth weir is higher than that of the linear weir, but lower than that of the trapezoidal weir.

Keywords: *Fluid Mechanics, Discharge Coefficient, Circular, Trapezoidal, Labyrinth Weir, Dam Safety*

1. Introduction

Generally a spillway consists of some type of control structure which is normally placed perpendicular to the flow direction. The capacity of spillway or a weir refers to the discharge for a given head of flow over its crest. Dams provide water supply (municipal, agricultural, industrial), flood control, hydropower, navigation, and recreation. Aging infrastructure, changes in land use, and higher peak flow predictions for extreme

flood events often require upgrading or rehabilitating existing spillways. The replacement of linear weirs with nonlinear weirs (labyrinth weirs in many cases) is often considered as an alternative for increasing spillway discharge capacity without increasing the existing spillway channel width. Labyrinth weirs provide an effective means to increase the spillway discharge capacity of dams and are often considered for renovation projects required due to an

¹ Nevsehir H.B.V. University, 5200, Nevsehir, Turkey, obilhan@nevsehir.edu.tr

² Fırat University, 23100, Elazığ, Turkey

increase in expected flood inflow to the reservoir of an existing dam. Due to the complex design of the overflow structure, the labyrinth spillway discharge

capacity is affected by many factors including weir geometry and approach channel conditions [1]. A labyrinth weir is a linear weir that is 'folded' in plan-view to increase the crest length for a given channel or spillway width [2]. Figure 1 provides the key details of the labyrinth weir. For relatively small dams (<8 m high), it is often economical to construct a "full height" labyrinth, where the base slab is at the level of the embankment foundation. This construction eliminates the need for a chute to convey flow to the downstream toe and also simplifies the foundation design since the labyrinth structure is founded on natural soil as opposed to new compacted fill, which is more prone to settlement.

In general, labyrinth weir cycles follow a linear configuration; however, the discharge efficiency of the weir may be improved by orienting the cycles to the approaching flow. According to [3], the efficiency of Prado Spillway could have been increased by arcing the cycle configuration. Examples of curved or arced labyrinth spillways are: Avon [4], Kizilcapinar [5].

Optimizing the many geometric variables in the hydraulic design of a labyrinth weir can be challenging. For example, the sidewall angle (α), total crest length (L_c), crest shape, number of cycles (N), the configuration of the labyrinth cycles, and the orientation and placement of a labyrinth weir must all be determined. Furthermore, the geometry of a labyrinth weir causes complex 3-dimensional flow patterns that must be considered. The flow rate passing over the labyrinth is dependent on the crest length, which can be

controlled by modifying the number of folds. The relationship between length and discharge is not linear, however, except for very small heads. As the water level above the labyrinth weir increases, four stages of nappe shape occur: fully aerated, partially aerated, transition and submerged. The thickness of nappe and depth of the tail water do not affect the discharge capacity of the labyrinth weir in the fully aerated flow condition. In this case, the labyrinth weir acts as a vertical cross section of the linear weir. As the water level above the labyrinth weir increases and the tail water rises, the nappe becomes partially aerated (adhering to the weir wall) and the discharge coefficient is reduced [5, 6].

Over the past 50 years, extensive research on the influence of geometric and hydraulic parameters on the hydraulic behavior of labyrinth weirs, particularly on the discharge capacity, has been completed. In [7], presented initial studies on the behavior of labyrinth weirs and presented the hydraulic performance as it compares with that of sharp-crested weirs. In [8], followed up on Taylor's work and developed design criteria for labyrinth weirs. Based on their research findings, they suggested Eq. (1) for the discharge coefficient of labyrinth weirs.

$$C_d = 3.22 + 0.40 \frac{h}{P} \quad (1)$$

where C_d is the discharge coefficient, h is the depth of flow over the weir crest and P is the weir height.

Additional work in [4] utilized the results from physical model studies to expand on the theory and develop a family of curves to evaluate spillway performance. Extensive physical model studies were performed in [9] to evaluate various labyrinth geometries and approach conditions. The U.S. Bureau of

Reclamation (USBR) tested a model of labyrinth spillway for Ute Dam and Hyrum Dam [9, 10]. They found that the discrepancy between their observations and those were caused by difference in head definition [8].

Case studies for Boardman Dam [11] and Hyrum Dam [10] reported that curved abutment walls upstream of the labyrinth weir minimized the loss of efficiency caused by flow separation. The test program for a 2-cycle labyrinth weir for Hyrum Reservoir in [10] included various weir orientations and placements (Normal, Inverse, Flush, and Partially Projecting). For similar entrance conditions, it was reported that the Partially Projecting orientation increased discharge by 10.4% when compared to the Flush orientation and the Normal orientation had a 3.5% greater discharge than the Inverted orientation [12].

In [13], has investigated model studies of the labyrinth weir and Eq. (2) is his suggested equation for calculation of discharge over labyrinth weirs.

$$Q = C_d \left(\frac{W_c}{\frac{P}{W_c}} \right) W_c H_t \sqrt{g H_t} \quad (2)$$

where Q is the discharge over labyrinth weir, C_d is the discharge coefficient, H_t is the total upstream head measured relative to the weir crest, W_c is the channel width and P is the weir height.

In [14], calculated discharge coefficient (C_d) of labyrinth weirs as function of L/w and H_t/P parameters. They defined discharge capacity of labyrinth weirs with Eq. (3).

$$Q = C_d W_T 2g H_t^{1.5} \quad (3)$$

In [15], carried out extensive experimental work on the performance of the labyrinth weir. They proposed a flow equation for the labyrinth weir that is identical to the basic equation applicable to a linear weir, but with modification of the coefficient of discharge. They also presented experimental data of the variation of discharge coefficient of labyrinth weir with a head to weir height ratio (H_t/P) for side wall angles (α) of 6° to 18° . Additional curves for weir side angles of 25° and 35° were obtained by extrapolation. In [16], extended this work by providing a dimensionless head-discharge relationship for submerged labyrinth weirs. Using a physical model of the labyrinth weir of Dog River Dam in Georgia, [17] showed that the method produced a discharge error up to $\pm 25\%$ [15].

Labyrinth weirs are also used as side weirs to increase the outflowing discharge. In [18] and [19] carried out extensive experimental work on the performance of the labyrinth side weirs and presented coefficient of discharge curves in a simplified way as compared to previous investigators. Further work on triangular labyrinth side weirs was completed by [20] using Artificial Neural Network (ANN) techniques to calculate the discharge coefficient under critical flow conditions.

In [18], studied the discharge coefficient of a semi-elliptical side weir in subcritical flow on a straight channel. The authors presented the discharge coefficient of the semi-elliptical side weir which is higher than that of the rectangular side weir, but lower than that of the triangular labyrinth side weir.

In [21], carried out flume studies on trapezoidal labyrinth weirs for side wall angles 6° , 8° , 10° , 16° , 21° , 26° and 30° . In [22], extended these studies for a wider range of flow conditions.

In [23], used laboratory-scale physical models to compare the hydraulic efficiency of the Piano Key (PK) weir design with that of a geometrically similar rectangular labyrinth weir, with and without sloping floors installed in the inlet and outlet keys. The test data showed that the PK weir was more efficient than the geometrically comparable rectangular labyrinth weir, a fact likely attributable to a reduction in entrance losses associated with the PK weir inlet key geometry.

In [24], studied the outflow process from a sharp-crested triangular labyrinth weir. Applying dimensional analysis and the Π theorem, five dimensionless parameters were determined as important to the description of the outflow process. A dimensionless stage-discharge relation was developed.

In [25], published labyrinth weir design equations that are applicable to in-channel labyrinth weir applications in which the approach flow is oriented normal to the weir crest axis. Consequently, some uncertainty exists regarding the hydraulic performance of labyrinth weir configurations that deviate from the experimental conditions associated with the empirical determinations.

In [26], investigated the labyrinth weir nappe interference and identified labyrinth weir flow characteristics that decrease discharge efficiency, including local submergence. The authors presented parametric methods for quantifying nappe interference region size as a function of weir geometry (e.g., sidewall angle and crest shape) and flow conditions (e.g., headwater and nappe aeration).

While all these documented studies have provided significant insights to the behavior of labyrinth weirs under specific conditions, the general theory remains: the capacity of

labyrinth weir is a function of the upstream total head, the effective crest length, and the coefficient of discharge. The discharge coefficient depends on the total head, weir height, thickness, crest shape, apex configuration, and angle of side wall. While viscosity and surface tension are also significant variables, their influence is limited at velocities of sufficient magnitude and by appropriate model geometries [23].

The purpose of this study is to systematically investigate the discharge capacity of sharp-crested circular labyrinth weir, using a broad range of experiments, and considered together with the other effective dimensionless parameters.

2. Experimental Set-up and Experiments

Semi-circular labyrinth weir experiments were conducted at the Hydraulic Laboratory of Firat University, Elazig, Turkey. Experiments were conducted at stable flow conditions and free overflow conditions. The experimental set-up includes sump, pumping system, discharge tank, rectangular flume, digital flowmeter and labyrinth weir (Fig. 1). Water is recirculated through 250 mm diameter of supply line using two 75 HP pumps. Water for experimental setup is taken from the supply line by means of a pipe with 150 mm diameter. The discharge was measured by means of a Siemens electromagnetic flow-meter installed in the supply line. Water was supplied to the main channel (2 m wide and 0.80 m height this channel length is 3.0 m) through a supply pipe from the sump (volume of 15 m³) with flow controlled by a gate valve. For damping the water surface waves and reducing turbulence, baffle wall and wood surface dampener is provided. In the experiments, the upstream elevation was built higher than the downstream elevation so that free flow conditions occur downstream of the weir.

Sheet metal materials which have 4 mm thickness (t) were used for labyrinth weirs. Labyrinth weirs designed as three-cycles. Schematic view of circular labyrinth weir is given in Fig. (2). Each semi-circular labyrinth weir and linear weir models with a sharp

crested shape was tested in the experiments (Examples shown in Fig. 3).

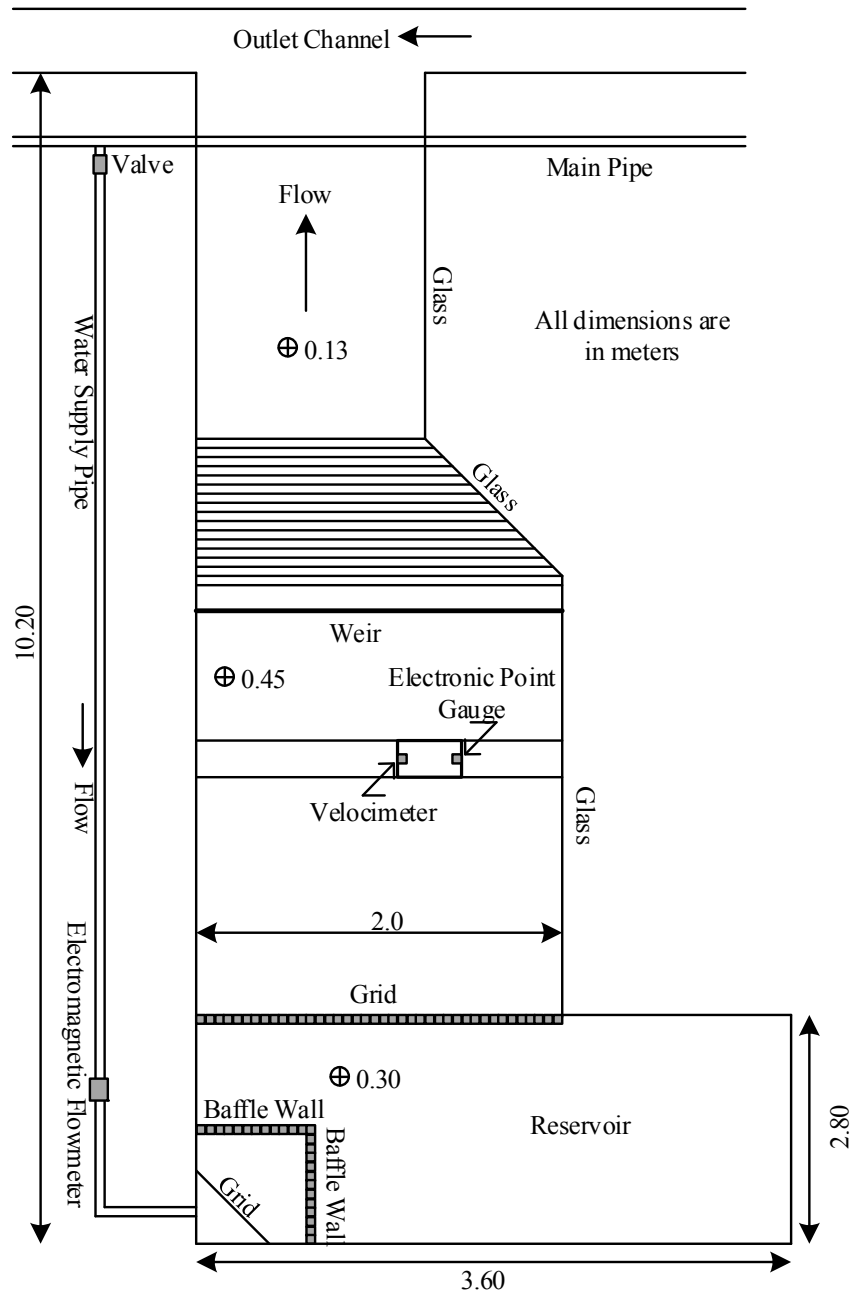

Fig. 1 Experimental arrangement

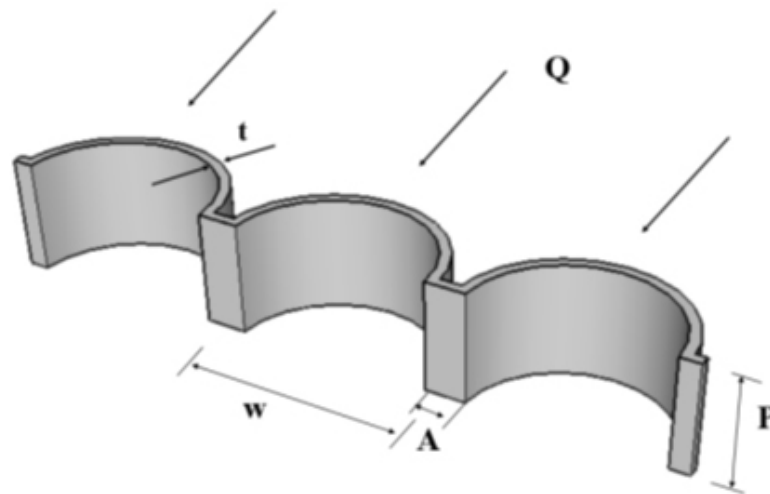
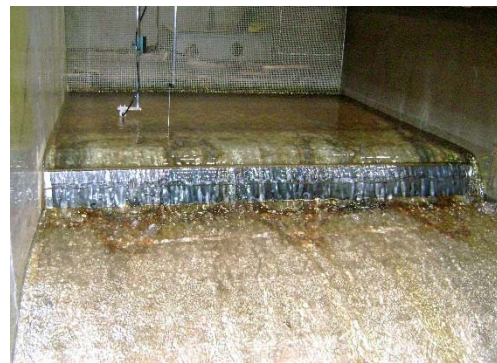

Fig. 2 Schematic view of the circular labyrinth weirs located on straight channel



Circular Labyrinth Weir



Linear Weir

Fig. 3 Experimental set-up for circular labyrinth weir and linear weir

To measure the nappe height, water depth was measured accurately using Mitutoyo digital point gauges (accurate to ± 0.01 mm) just upstream of the weirs. Level measurements were taken at a distance from the weir equal to five times the nappe height. For flow rate measurements, Nortek brand acoustic three-axis velocimeter was used.

In the experiments, the weir heights were taken as 100 mm, 150 mm and 200 mm and apex width (A) was taken as 80 mm. Sharp-

crested shapes is provided for all models. All experiments were performed according to free flow conditions.

The flow over labyrinth weir is three dimensional and does not readily fit into mathematical description and hence the discharge function is found through experimental studies and analysis. The crest coefficient depends on the total head, weir height, thickness, crest shape, apex configuration and angle of side wall. To

simplify the analysis, the effect of viscosity and surface tension could be neglected by selecting model and velocity of sufficient magnitude.

The discharge over labyrinth weir can be expressed as:

$$Q = \frac{2}{3} C_d \sqrt{2g} H_t^{1.5} L \quad (4)$$

where Q is the discharge over a labyrinth weir; C_d is the discharge coefficient of the labyrinth weir; L is the effective length of labyrinth weir; H_t is the total head ($V_0^2/2g + h$) and g is the gravitational acceleration constant (Fig 4).

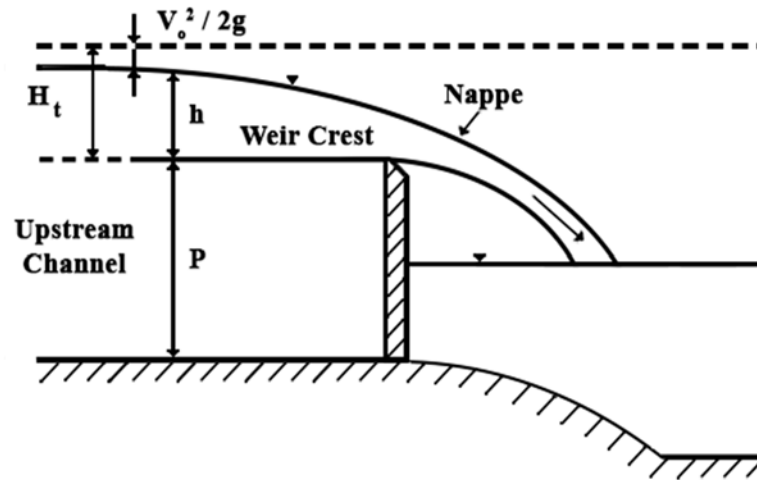

Fig. 4 Definition sketch for flow over a sharp crested weir

Head over labyrinth weir was measured for different value of discharges in the range of 14.7 L/s to 136.9 L/s. In this range, the head over the labyrinth weir varied from 10 to 90 mm. The models of linear weir a trapezoidal labyrinth weirs are also tested in the same

Flume for the purpose of comparison. In the experiments, the characteristics of the circular labyrinth weirs, trapezoidal labyrinth weirs and linear weirs which are tested in the experiments are given in Table 1.

Table 1. Physical model geometrics for labyrinth weirs tested in the present study

Models	W_c (cm)	P (cm)	L (cm)	N	A (cm)	L_c/w	Type of Weir
1	196	10	196	-	-	-	Linear Weir, $\alpha=90^\circ$
2	196	15	196	-	-	-	Linear Weir, $\alpha=90^\circ$
3	196	20	196	-	-	-	Linear Weir, $\alpha=90^\circ$
4	196	10	294	3	8	1.50	Circular Labyrinth Weir
5	196	15	294	3	8	1.50	Circular Labyrinth Weir
6	196	20	294	3	8	1.50	Circular Labyrinth Weir
7	196	10	294	3	8	1.50	Trapezoidal Labyrinth Weir, $\alpha=37^\circ$
8	196	15	294	3	8	1.50	Trapezoidal Labyrinth Weir, $\alpha=37^\circ$
9	196	20	294	3	8	1.50	Trapezoidal Labyrinth Weir, $\alpha=37^\circ$

3. Experimental Results and Analysis

Experiments are carried out on three circular labyrinth weir models, and three linear weir models having sharp crested shape similar to labyrinth weirs models. Moreover, the results of the present study compared well with trapezoidal labyrinth weirs and linear weirs as shown in Fig. 5 and Fig. 6. On all these models, head-discharge measurements are taken for weir height of $P=10, 15$ and 20 cm. A total of 9 different configurations were examined in these experiments.

Discharge coefficient for labyrinth weirs was computed using equation (Eq. (4)). Discharge coefficients of circular labyrinth side weirs have much higher values than the conventional weirs. The effect of crest shape on the discharge coefficient is very significant for the same channel width and crest length.

When the weir is placed at an acute angle to the flow, the flow becomes three dimensional. For linear weirs, all the streamlines are perpendicular to the crest and

are two-dimensional. But for inclined weir, like a labyrinth weir, the streamlines under the nappe are almost perpendicular to the crest, whereas at the free water surface the streamlines are pointing towards the downstream direction. The labyrinth weir flow becomes further complicated due to interference of jets near the upstream apex of the labyrinth. At high discharges, the jets from adjacent crests strike each other and in the process create a nappe that is not aerated. This results in decrease of discharge coefficient of the labyrinth weirs.

From the present experiments results, the variation of C_d for circular labyrinth weirs with H/P is plotted for $P=10, 15$ and 20 cm in Fig.5. It is noted that discharge coefficient for labyrinth weirs is computed using equation (Eq. (4)). It is apparent from the results in Fig. 5 and Fig. 6 that discharge capacity of the labyrinth weirs is much higher than the conventional weirs. The primary reason for this is that the crest length of the labyrinth weir is much longer than that of the conventional weir.

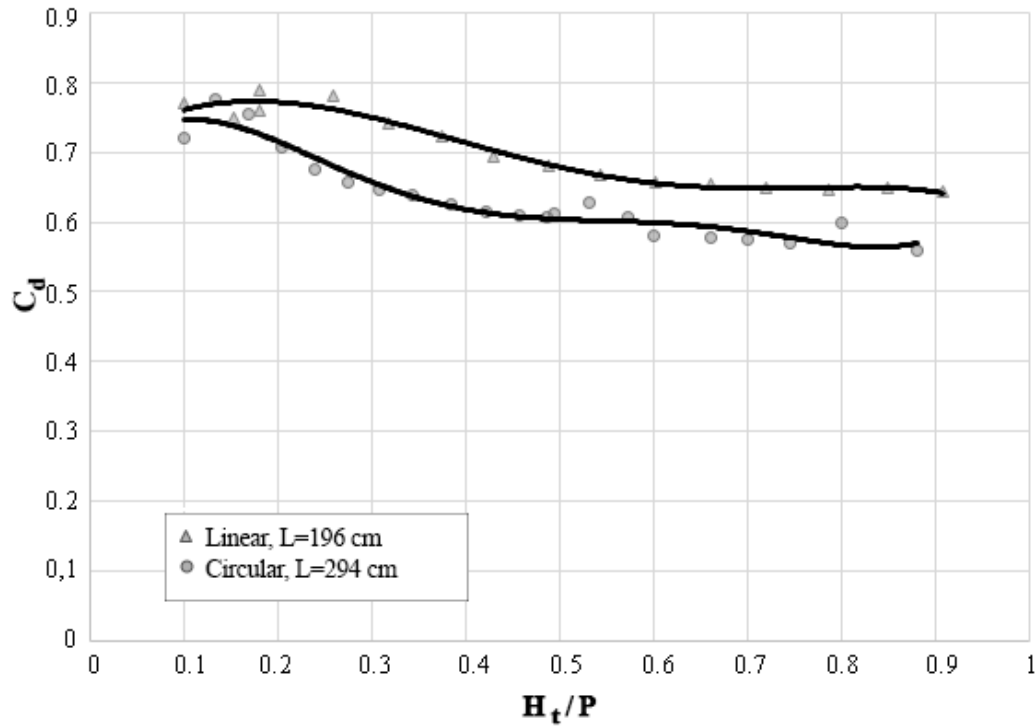

Fig. 5 Variation of discharge coefficient (C_d) with Head to weir height (H_t/P) for circular and linear weirs

Also, the variation of discharge coefficient (C_d) with head to weir height (H_t/P) for trapezoidal labyrinth weir ($\alpha=37^\circ$, $L=294$ cm, $N=3$, $P=10-15-20$ cm) and circular labyrinth weir ($L=294$ cm, $N=3$, $P=10-15-20$ cm) which have the same crest length is plotted in Fig. 6.

The discharge capacity of trapezoidal labyrinth weir according to the circular labyrinth weir can be seen to be higher in Fig. 6. This results especially can be seen in the H_t/P values between 0.1 to 0.6.

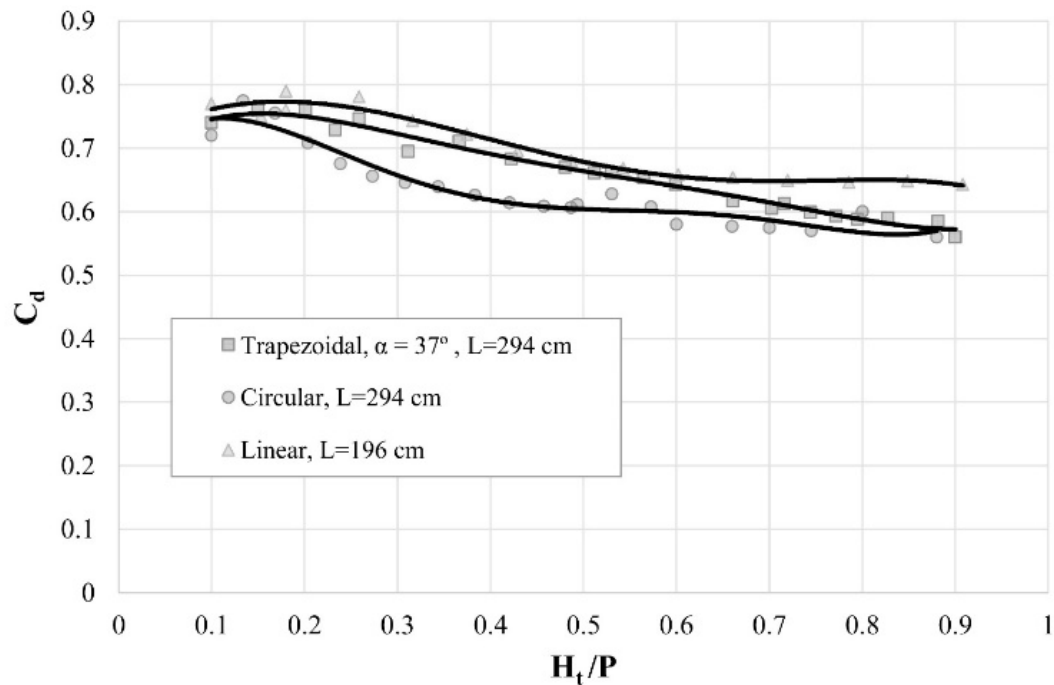

Fig. 6 Variation of discharge coefficient (C_d) with head to weir height (H_t/P) for trapezoidal, circular labyrinth weirs and linear weir

In Fig. 6, the sudden decrease in weir efficiency varies (caused by the weirs shifting out of the clinging nappe aeration regime) but is present for all tested sharp-crested weirs in the range from 0.3 to 0.5 of H_t/P .

To represent the data of the equation form, correlation analysis is carried out for the observed data for each model, separately. The 5th degree polynomial provides a reasonable fit between C_d and H_t/P . Thus, discharge coefficient (C_d) of sharp-crested labyrinth weir is expressed as:

$$C_d = A_0 + A_1 \left(\frac{H_t}{P} \right) + A_2 \left(\frac{H_t}{P} \right)^2 + A_3 \left(\frac{H_t}{P} \right)^3 + A_4 \left(\frac{H_t}{P} \right)^4 + A_5 \left(\frac{H_t}{P} \right)^5 \quad (5)$$

The values of C_d for circular labyrinth weirs and linear weirs, A_0 to A_5 and R^2 are shown in Table 2.

Table 2. Coefficient of discharge per unit length of circular labyrinth weirs

Model	A_0	A_1	A_2	A_3	A_4	A_5	R^2
Circular	0.6416	2.2646	-	38.676	-	16.310	0.9239
Linear	0.6991	0.9370	15.683	2.4939	41.490	-	0.9665
			-		1.8340	1.9528	
			3.4166				

4. Conclusions

Labyrinth weirs provide an effective means to increase the spillway discharge capacity of dams and are often considered for renovation projects required due to an increase in expected flood inflow to the reservoir of an existing dam. The hydraulic performance of traditional labyrinth weirs is well known since they have been studied for a long time. Nevertheless, analytical design equations considering all the involved parameters are not yet available. The design has to be based on experimentally derived and generalized performance curves.

According to this experimental study, it was found that the trapezoidal labyrinth weirs are hydraulically more efficient than the circular labyrinth weirs and linear weirs from the perspective of ease of construction and the discharge capacity.

The values for discharge coefficient of circular labyrinth weir and linear weir can be suitably obtained from the design curves and the regression equations generated through this study.

Of course, given unlimited width, greater efficiencies (discharge per head) will be obtained for a linear weir. However, the trapezoidal labyrinth weirs provides much greater weir length in confined space with

only limited reductions in efficiency (reduction in C_d). The circular weir is the least efficient of those investigated.

It was found that the discharge coefficient of circular labyrinth weir C_d increases when the L ratio and number of labyrinth weir cycles (N) increases. The discharge coefficient of the circular labyrinth weir is higher than that of the linear weir, but lower than that of the trapezoidal weir.

It is recommended that a labyrinth weir design be verified with a physical or numerical model study, as it would include site-specific conditions that may be outside the scope of this study and may provide valuable insights into the performance and operation of the labyrinth weir.

Variation of the nappe pressure between sub-atmospheric pressure and atmospheric pressure causes vibrations, oscillations and noise. Although the negative pressures under water nappe partially increase the discharge capacity of the labyrinth weirs, effects of vibration and resonance may cause problems that could threaten the safety of the structure.

The authors are continuing research using nappe breakers to model non-standard labyrinth geometries and approach conditions

for increasing discharge capacity of labyrinth weirs.

Acknowledgment

Funding for this study was provided by the Scientific Research Project Department of Firat University in Turkey, Project No: 1610.

NOTATION

A	Apex width;
C_d	Discharge coefficient;
g	Acceleration constant of gravity;
h	Depth of flow over the weir crest;
H_t	Total upstream head measured relative to the weir crest;
H_t/P	Headwater ratio;
N	Number of labyrinth weir cycles;
P	Weir height;
Q	Discharge over weir;
V	Average cross-sectional flow velocity stream of weir;
W_c	Channel width;
w	Width of a single labyrinth weir cycle;
L	Total crest length of labyrinth weir;
L_c	Total crest length for a single labyrinth weir cycle;
R^2	Determination coefficient;
t	Weir wall thickness.

REFERENCES

- [1] Yıldız D., Uzuçek E. (1993) Labirent dolusavakların projelendirilme kriterleri. Devlet Su İşleri Teknik Araştırma Kalite ve Kontrol Dairesi Başkanlığı. Yayın No: HI-862 Ankara.
- [2] Crookston, B. M., and Tullis, B. P. (2012c) Labyrinth weirs: Nappe interference and local submergence. *J. Irrig. Drain. Eng.*, 138(8), 757–765.
- [3] Falvey, H.T., (2003) Hydraulic Design of Labyrinth Weirs. ASCE Press, 162p.
- [4] Darvas, L. (1971) Discussion of performance and design of labyrinth weirs, by Hay and Taylor. *J. Hydraul. Eng.*, ASCE, 97(80), 1246–1251.
- [5] Yıldız, D., Uzuçek, E. (1996) Modeling the performance of labyrinth spillways. *Int. J. Hydropower Dams*, 3, 71–76.
- [6] Tsang, C. (1987) Hydraulic and aeration performance of labyrinth weirs. Ph.D. dissertation, University of London, London.
- [7] Taylor, G. (1968). The performance of labyrinth weirs. PhD thesis, University of Nottingham, U.K.
- [8] Hay, N., and Taylor, G. (1970) Performance and design of labyrinth weir. *J. Hydraul. Eng.*, 96(11), 2337–2357.
- [9] Houston, K. (1982) Hydraulic model study of Ute dam labyrinth spillway. Rep. No. GR-82-7, U.S. Bureau of Reclamation, Denver.
- [10] Houston, K. (1983) Hydraulic model study of Hyrum dam auxiliary labyrinth spillway. Rep. No. GR-82-13, U.S. Bureau of Reclamation, Denver.
- [11] Babb, A. (1976). “Hydraulic model study of the Boardman Reservoir Spillway.” R.L Albrook Hydraulic Laboratory, Washington State University, Pullman, Wash.
- [12] Crookston, B. M., and Tullis, B. P. (2011) “The design and analysis of labyrinth weirs” 31st Annual USSD Conference. San Diego, California, April 11-15, Pages: 1667-1681.
- [13] Lux, F., (1989) Design and Application of Labyrinth Weirs, Design of Hydraulic Structures 89, Balkema, Rotterdam, ISBN, 90, 6191 – 8987.
- [14] Magalhaes, A., and Lorena, M. (1989) Hydraulic design of labyrinth weirs. Rep. No. 736, National Laboratory of Civil Engineering, Lisbon, Portugal.

- [15] Tullis, B. P., Amanian, N., and Waldron, D. (1995) Design of labyrinth weir spillways. *J. Hydraul. Eng., ASCE*, 121(3), 247–255.
- [16] Tullis, B. P., Young, J., and Chandler, M. (2007) Head-discharge relationships for submerged labyrinth weirs. *J. of Hydraul. Eng., ASCE*, 133(3), 248–254.
- [17] Savage, B., Frizell, K., and Crowder, J. (2004) “Brains versus brawn: The changing world of hydraulic model studies”. ASDSO 2004 Annual Conf. Proc., Association of State Dam Safety Officials (ASDSO), Lexington, KY. May, 4. (www.usbr.gov/pmts/hydraulics_lab/pubs/PAP/PAP-0933.pdf).
- [18] Emiroglu, M. E., Kaya, N., and Agaccioglu, H. (2009). “Discharge capacity of labyrinth side weir located on a straight channel.” *J. Irrig. Drain. Eng., ASCE*, 136(1), 37–46.
- [19] Kaya, N., Emiroglu, M. E., and Agaccioglu, H., (2011) “Discharge coefficient of a semi-elliptical side weir in subcritical flow.” *Flow Measurement and Instrumentation*, Volume: 22, 25-32.
- [20] Bilhan, O, Emiroglu, M. E., Kisi, O, (2011) Use of artificial neural networks for prediction of discharge coefficient of triangular labyrinth side weir in curved channels. *J. Advances in Eng. Soft.* 42(4), 208-214.
- [21] Khode, B.V., Tembhurkar, A.R. Porey, P.D. and Ingle R.N. (2011) Determination of Crest Coefficient for Flow over Trapezoidal Labyrinth Weir. *World Applied Sciences Journal* 12 (3): 324-329.
- [22] Khode, B. V., Tembhurkar, A. R. P. D. Porey and R. N. Ingle, (2012) Experimental Studies on Flow over Labyrinth Weir. *Journal of Irrig. Drain Eng. ASCE*, 138:548-552.
- [23] Anderson, R. M. and Tullis, B. P., (2012) Comparison of Piano Key and Rectangular Labyrinth Weir Hydraulics. *J. Hydraul. Eng.* 138:358-361.
- [24] Carollo, F., Ferro, V., and Pampalone, V. (2012). Experimental Investigation of the Outflow Process over a Triangular Labyrinth-Weir. *J. Irrig. Drain Eng.*, 138(1), 73–79.
- [25] Crookston, B. M., and Tullis, B. P. (2012a) Arced labyrinth weirs. *J. Hydraul. Eng.*, 138(6), 555–562.
- [26] Crookston, B. M., and Tullis, B. P. (2012b) Discharge efficiency of reservoir-application-specific labyrinth weirs. *J. Irrig. Drain. Eng., ASCE*, 138(6), 773–776.