

Control of Fuel Cell Power System

Ayşe KOCALMIS BILHAN¹

Caisheng WANG²

Abstract

In recent years, it is getting attention for renewable energy sources such as Fuel Cell (FC), batteries, ultracapacitors or photovoltaic panels (PV) for distributed power generation systems (DG) or electrical vehicles. This paper proposes a DC/DC converter and DC/AC inverter scheme to combine the Fuel Cell Stack (FC). The power system consist of a FC stack, a DC/DC converter, inverter and load. A FC mostly could not produce necessary output voltage, the DC/DC boost converter is used for obtaining the desired output voltage. The inverter is used for many applications such as electrical vehicles (EV) and distributed generation systems (DG). In this paper, sinusoidal pulse modulation technique and space vector pulse width modulation technique have been simulated and compared for electrical vehicles applications.

Keywords: *Converters, Fuel Cells, Electrical Vehicles*

1. Introduction

Increasing human population brings some requirements such as clean water, clean air and much more electrical energy [1]. Also many research results show that fossil-based energy sources have become running out and also fossil-based energy sources cause to environmental pollution (air, ozone hole and etc.). In the last decade, more attentions have been given to renewable energy technologies such as solar, wind, geothermal, biomass, hydraulic and FCs. Advantages of all these kind of energy sources are that they do not run out and do not cause environmental damages due to the usage of fossil energy sources such as coal, natural gas and etc. In the near future, they will be the answer for addressing

pollution, global warming, potential energy crisis, and etc. Recently all renewable energy technologies are very popular and widely used around the world.

FCs can be used as a primary energy source for distributed power generation (DG) [2], electrical vehicles (EV), residential application or transportation because of they can be fabricated without environmental pollution or efficiency. It can be considered as a voltage sources or a power plant or a battery. FCs are electrochemical energy converter which convert chemical energy of a fuel directly into an electrical energy. It is very clean energy source because of water is only by-product. The output power generating

¹ Nevsehir H.B.V. University, Nevsehir, Turkey, akbilhan@nevsehir.edu.tr

² Wayne State University, MI, USA

capacity can be easily increased by adding more FC modules. Advantages of FCs can be listed as [3];

- High efficiency,
- High reliability,
- Not-moving part, and modular
- Do not cause pollution.

The main source of FC is hydrogen. The hydrogen (H_2) is the most abundant element but unfortunately it does not appear naturally in a useful form. Almost half of hydrogen is produced by steam reforming of natural gas. The other methods of producing hydrogen are electrolysis of water, conversion of coal to H_2 , use of biomass energy to produce H_2 , use of nuclear energy (NE) to produce H_2 or use of solar energy to produce H_2 .

This paper describes design of suitable control strategies for FC DG systems to keep system stable with RL load. A Matlab/Simulink model is built in the proposed work.

A FC has an electrolyte layer between an anode and a cathode electrodes. In the literature many FCs structures have been developed and they are classified according to types of electrodes and electrolytes used inside [4]: Proton Exchange Membrane FC (PEMFC), Solid Oxide FC (SOFC), Molten Carbonate FC (MCFC), Phosphoric Acid FC (PAFC), Alkaline FC (AFC) and etc. [5]. A schematic representation of a FC is shown in Fig. 1.

PEMFCs are commonly known as proton exchange membrane fuel cells which are used

a solid polymer as electrolyte. This electrolyte is an excellent conductor of protons and an insulator of electrons the overall reaction of PEMFC can be summarized with Eq. (1), (2) and (3). These reactions proceed continuously.

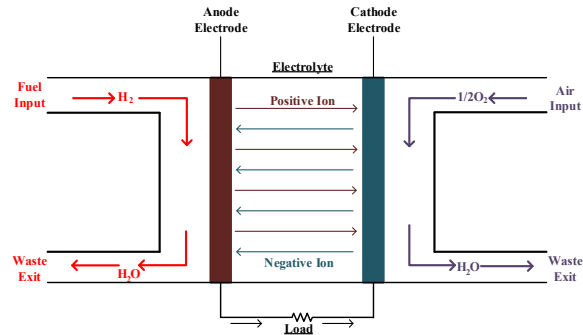
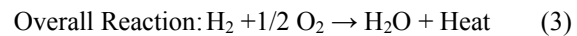
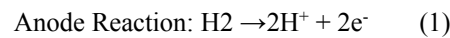

Fig.1 A schematic representation of a FC



PEMFCs have been used in worldwide in many type applications such as hospitals, shelters, offices, hotels and schools [6]. PEMFCs can be used either main power sources or back up units. Each cell in a FC stack has a low output voltage (around 1V at full load), it is necessary to stack many in series to obtain a reasonable output voltage. For low power applications the number of cells that needs to be connected in series is small, but as power increases the number of cells that are required in the stack increases rapidly and it is called as a FC Power Plant (FCPP). In Fig. 2, a basic diagram of a FCPP has been shown. Also numbers of usage FC can be calculated by using Eq. (4) and Eq. (5)

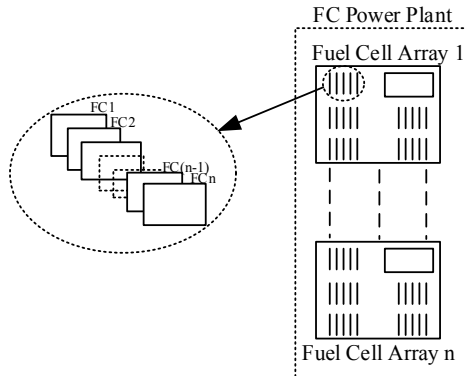

Fig.2 The basic diagram of FCPP

$$N_s = \frac{\text{FC System Voltage}}{\text{FC Stack Voltage}} \quad (4)$$

$$N_p = \frac{\text{FC System Power}}{\text{FC Stack Power}} \quad (5)$$

The main purpose of using FCs is to produce stable DC output voltage independent of the load current. Unfortunately, the FC mostly could not produce necessary output voltage. Also a FC has not storage capability, response slowly and the output voltage has ripples with loads. For these reasons in many applications show that a FC stack needs a supporting system [6] such as DC/DC converter, ultracapacitors (UC), high voltage battery and/or energy management systems.

2. The Fuel Cell Power System

In Fig. 3, Block diagram of whole system has been shown. “Fuel Processing Unit” and “Fuel Cell” blocks produce DC voltage by using fuel and air. In the “Power Conversion Unit” block, the output voltage of FC is increased by using DC/DC boost converter and converted to AC output voltage by using DC/AC converter. Finally, “Control Unit” block control switching signals of DC/DC and DC/AC converters.

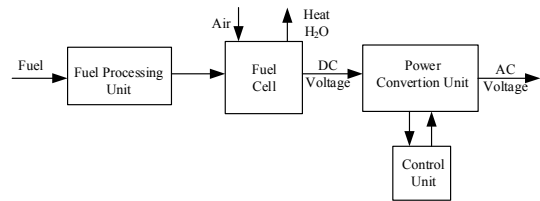

Fig.3 Block diagram of whole system

2.1. Fuel Cell

A FC equivalent circuits are shown in Fig. 4 [7]. V_{cell} (concentration), V_{actcell} (activation), V_{ohmcell} (ohmic) show voltage drops in FC in Fig. 4(a). These voltage drops are functions of load current and FC temperature or pressure. E_{cell} and V_{cell} are reversible voltage and output voltage of FC, respectively.

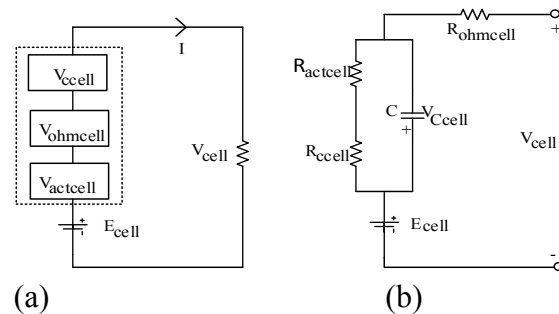

Fig. 4 FC (a) equivalent circuit, (b) equivalent electric circuit

R_{ohmcell} (ohmic resistance) is a function of FC temperature. R_{cell} and R_{actcell} are resistances of concentration and activation voltage components, respectively. The output voltage of a single cell can be calculated by using Eq. (6) [8]. In this paper, the output voltage of the FC is 38,1V.

$$V_{\text{cell}} = E_{\text{cell}} - V_{\text{actcell}} - V_{\text{ohmcell}} - V_{\text{cell}} \quad (6)$$

In Eq. (6), E_{cell} is called as Nernst’s voltage and it is calculated as Eq. (7);

$$E_{cell}=1.229-0.85 \times 10^{-3}(T-T_{ref})+4.31 \times 10^{-5} T(\ln(P_{H_2})+0.5 \ln(P_{O_2})) \quad (7)$$

where T_{ref} represents the reference temperature, the P_{H_2} represents the hydrogen, P_{O_2} the oxygen partial pressure, and T represents the cell temperature in K.

2.2. DC/DC Boost Converter

It is necessary to control the output voltage of FC to connect grid. The DC/DC converter boost the voltage, control the FC power and regulate the voltage in the FC applications. In Fig.5, DC/DC boost converter model has been shown.

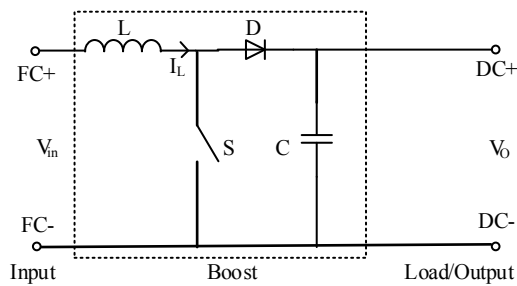

Fig.5 Model of DC/DC Boost Converter

In the boost converter, Eq. (7) and Eq. (8) show if the switch (S) is on and Eq. (9) shows if the switch (S) is off;

$$V_i = \frac{L di_L}{dt} \quad (7)$$

$$V_c = V_o \quad (8)$$

$$V_i = \frac{L di_L}{dt} + V_o \quad (9)$$

By using Eq. (7), (8) and (9), duty cycle (d) of DC/DC boost converter can be calculated as in Eq. (10).

$$V_i = \frac{V_o}{d-1} \quad (10)$$

In this paper, the boost converter has following parameters; $L=3\text{mH}$ and $C=200\mu\text{F}$. The nominal duty cycle (d) of the boost converter is $2/3$. The feedback control of the system has shown in Fig. 6. In this controller K_p is 0.002 and K_i is 0.2.

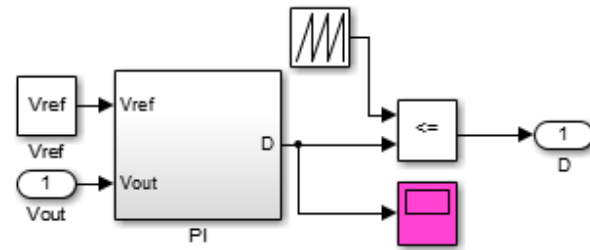

Fig.6 PI Control Structure

2.3. DC/AC Inverter

The inverter convert dc power into ac power with desired magnitude and frequency [9]. It provides flexibility usage of FC in real applications. In Fig.7, the dynamic model of voltage source inverter (VSI) has been shown. The three Phase DC/AC inverter circuit consist of 6 active switches. In the each phase, two IGBT switches are used. The switching frequency is 1,5k Hz.

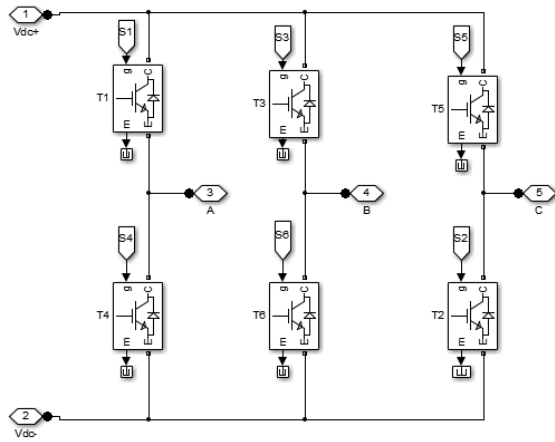

Fig.7 Three Phase DC/AC VSI Inverter

In the literature, several control techniques have been developed such as sinusoidal pulse width modulation (PWM), space vector PWM, sigma-delta PWM and etc [10] for producing output voltage. In the simulation, the output frequency is used as 50Hz, and modulation index of the inverter is used as 0.8.

3. Modelling and Simulation

The performance of the proposed system is simulated by using Matlab/Simulink package program as seen in Fig. 8.

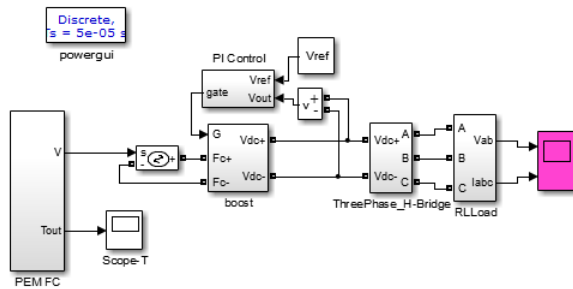

Fig.8 Matlab/Simulink model of whole system

As it seen from Fig. 8, the output voltage of FC cannot be used directly; therefore a step up converter as a boost converter is used. The H-bridge inverter structure is used to convert DC

voltage to AC voltage. Finally, a three phase RL load is feed by an inverter structure. In the simulation, $R=100\Omega$ and $L=0.1H$ are used as a passive load.

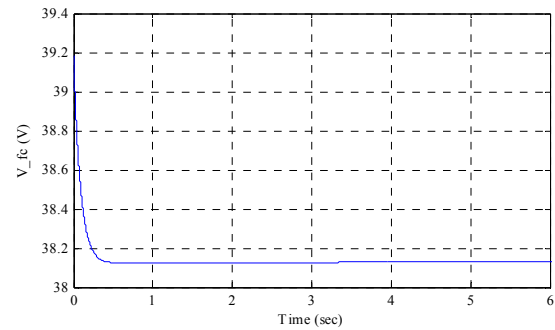

Fig. 9 The output voltage of FC

The output voltage of FC has been shown in Fig. 9 [11] and the output voltage of DC/DC boost converter has been shown in Fig. 10. The duty cycle (d) of the converter is chosen as a 2/3, so the output voltage of the converter is 114,3V.

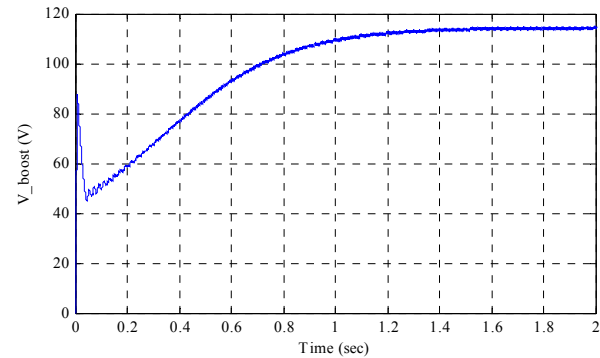

Fig. 10 The output voltage of DC/DC boost converter

The single phase output line current, three phase output current and the line voltage waveforms have been shown in Fig. 11, Fig. 12 and Fig. 13, respectively.

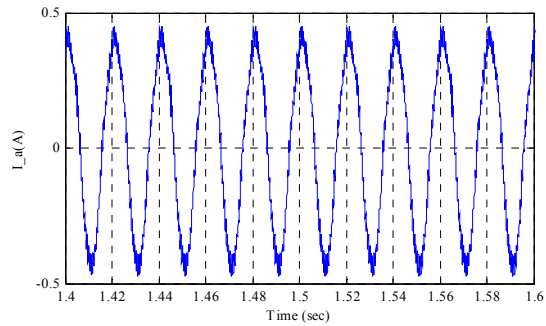

Fig. 11 The single phase output current waveform,
 I_a (A)

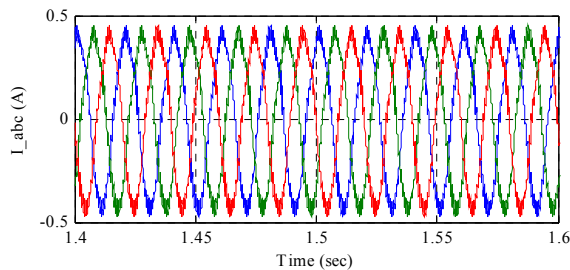

Fig. 12 Three phase output current waveforms,
 I_a, I_b, I_c (A)

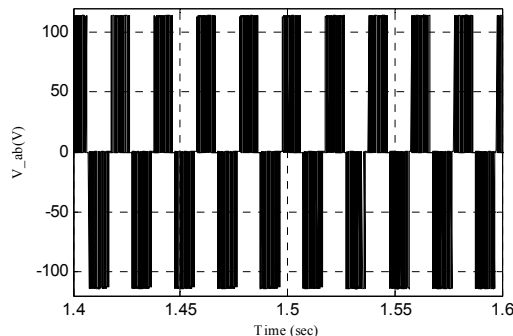

Fig. 13 The three phase output voltage waveform,
 V_{ab} (V)

4. Conclusions

A FC power system should be used as a main power source in the near future for DG, EV or portable applications due to it is difficult to

find H_2 in useful form and expensive cell components.

In this paper, a FC power system with DC/DC converter and DC/AC inverter is described. The output voltage of FC is considered constant value as 38,1V and the feedback control of DC/DC boost converter has been designed and simulated for the FC power system. By using three phase inverter, it is easy to control output voltage and current.

Recent researches show that improvements of the FCs control algorithms will be getting attention. Also the output voltage control of DC/DC boost converter will be considered in the future works.

Acknowledgement

This work was supported in part by the Scientific and Technological Research Council of Turkey (TUBITAK).

REFERENCES

- [1] K. W. E. Cheng, D. Sutanto, Y. L. Ho, and K. K. Law, "Exploring the power conditioning system for fuel cell," in *Proc. IEEE PESC*, 2001, pp. 2197–2202.
- [2] Wang, C., Nehrir, M., H., Gao, H., "Control of PEM Fuel Cell Distributed Generation Sytems", *IEEE Trans. on Energy Conversion*, Vol. 21, No.2, pp. 586-595, 2006.
- [3] K. Jin, X. Ruan, M. Yang, M. Xu, "A Hybrid Fuel Cell Power System", *IEEE Trans. on Industrial Electronics*, Vol. 56, No.4, pp: 1212-1222, 2009.

- [4] Kumar, T. P., Subrahmanyam, N., Syduu, M., “Control Strategies of a Fuzzy Controlled Solid Oxide Fuel Cell/Battery Distributed Generation System for Power Quality Enhancement”, *International Conf. on Circuit, Power and Computing Tech. (ICCPCT)*, pp. 64-69, 2014.
- [5] Chaudhary, S., Chauhan, Y.K., “Studies and Performance Investigations on Fuel Cells”, *IEEE International Conference on Advances in Engineering & Technology Research (ICAETR - 2014)*, August 01-02, 2014, India.
- [6] Barbir F., “PEM Fuel Cells: Theory and Practice”, Elsevier, *Academic Press Sustainable World Series*, 2005.
- [7] Nehrir, M. H., Wang, C., “Modeling and Control of Fuel Cells”, Wiley, *IEEE Pres.*, 2009.
- [8] Milanovic, M., Rodic, M., Truntic, M., “DC-DC Conditioning System for FC application”, *EPE/PEMC Conference*, pp: DS3d.3-1-DS3d.3-5, 4-6 Sept 2012.
- [9] Wu, B. “High-Power Converters and AC Drivers”, *The Institute of Electrical and Electronics Engineering*, 2006.
- [10] M. H. Rashid, “Power Electronics Handbook”, *Academic Press*, New York, 2001.
- [11] Wang, C., Nehrir, M., H., Shaw, S.R., “Dynamic Models and Model Validation for PEM Fuel Cells Using Electrical Circuits”, *IEEE Trans. on Energy Conversion*, Vol. 20, No. 2, pp. 442-451, 2005.